

FREQUENCY, RATE, TOTAL AND TIME FUNCTIONS

**MODEL
HI-QCPM**

FUNCTIONS:

- Frequency
- Period
- Rate
- Total
- Time Interval
- Stop Watch
- Phase Angle
- Square Root
- Integrating Totalizer
- Up/Down Totalizer
- Ratio
- A+B,A-B,A*B,A/B
- Draw
- Batching
- Quadrature
- Custom Curves



FEATURES:

- Simple setup by pushbuttons or computer
- 1/F frequency measurements for fast control response and true peak reading
- Measures rate and total simultaneously
- 2 channel pulse or AC input with separate scale and offset
- Voltage-to-frequency converter for rate and total
- Quadrature X, Y, Z inputs for differential or single-ended encoders
- Scalable in engineering units
- Worldwide input power from 85 to 264 VAC and 90 to 370 VDC
- 5, 10 or 24 VDC output to power sensors

PLUG-IN OPTIONS

- **Dual setpoint Controller:**
10 Amp, 250VAC relays or isolated transistor outputs
- **Isolated Linearized Analog Outputs:**
0 to 10VDC and 0 to 20mA
- **Isolated Digital Communications:**
RS-232 for interface and meter setup
RS-485 to interface with multiple meters
Baud rates from 300 to 19,200
- **Isolated Low Voltage Power Supply:**
9 to 37VDC and 8 to 28VAC inputs
Isolated 5, 10 or 24VDC output

The HI-QCPM is a low cost solution to a wide range of monitoring and control applications. By simple front panel push-button setup, one meter with a dual channel signal conditioner can be programmed to display frequency or period of the AC line, flow rate and total flow, RPM, time interval phase angle, ratio of the 2 signals or batch values. Independent span and zero for each channel allows two separate inputs to be calculated at the same time. Either of the 2 inputs or the sum, difference, etc., may then be displayed by front panel pushbutton selection. The voltage-to-frequency input signal conditioner converts the meter to an integrating totalizer or rate meter for voltage or current inputs. Outputs may be scaled to display watts and total kilowatt hours, flow and total flow. The square root function provides direct readout of differential pressure transducers. Custom curves may be programmed in the meter for accurately measuring nonlinear frequency or voltage inputs. The quadrature input board is designed to measure position from encoders with differential or single-ended outputs. The quadrature inputs may be up to 200kHz. A zero index input is available for zero correction.

The HI-QCPM measures the period of the input and converts the reading to frequency or rate for fast control response, true peak reading capability and an analog output that accurately tracks the signal input. The meter has a gate time selectable from 10mS to 199.99S and an adaptive digital filter that minimizes noise but yet, responds rapidly to an actual change in signal level. The peak value of the input signal can be displayed by pushing a front panel button. The HI-QCPM provides an isolated 5, 10 or 24VDC output to power sensors.

Transistors or dual 10 amp relays may be added to provide control outputs with the setpoints programmed by front panel pushbuttons. The outputs can be set to operate above or below the setpoint, as deviation alarms and in a latched or nonlatching mode.

0 to 10V and 0-20mA analog outputs are available to drive chart recorders, remote displays or for transmission to a central control room. The outputs are scaled through the front panel pushbuttons.

Adding RS-232 or RS-495 enables the HI-QCPM to communicate with PLC's or computers. Baud rates can be set from 300 to 19,200. With these options, this makes meter setup even easier.

520-748-7900

FAX: 520-790-2808
E-MAIL: sales@otekcorp.com
http://www.otekcorp.com

OTTEK™
CORP.
SINCE 1974
1

4016 E. TENNESSEE ST.
TUCSON, AZ. 85714 U.S.A.
MADE
IN
USA



SPECIFICATIONS

Display
 Type: 6 LED, 7-segment,
 14.2mm (.56") high digits and 4 LED indicators
 Color Red or green
 Range -999999 to +999999
 Conversion Technique
 (Frequency) 1/period time
 Rate Gate Time + 30ms + 2
 periods of the input signal (max.)
 Gate Time Selectable 0 to 199.99 Sec.
 Accuracy at 25°C
 FR Option
 Inputs AC or Pulses from NPN,
 PNP xistors, contact closures, magnetic pickups,
 etc.
 Channel A 0 to 2mHz
 Channel B 0 to 250kHz
 Time Base (crystal) Calibrated to +/-2PPM
 Span Tempco +/-PPM(°C (typ)
 Zero Tempco 0.001%FS/°C

QD Options
 Inputs Differential or single-
 ended inputs from quadrature encoders, Input
 to 250kHz
 Error No error contributed by
 meter
 CMV (DC to 60 Hz) Safety-rated to 250VAC
 4.2kVp per High Voltage Test
 Environmental
 Operating Temperature 0° C to 55°C
 Storage Temperature -40°C to 85°C
 Relative Humidity 95% at 40°C,
 noncondensing
 NEMA4X when mounted in
 panel
 Operating Power
 Voltage (std.) 85 to 264VAC, 90
 to 370VDC

Voltage (opt) 8 to 28VAC,
 9 to 37VDC
 Frequency DC and 47 to
 440Hz
 Excitation Power Supplies
 Outputs 5VDC, 5%,
 100mA max.
 10VDC, 5%, 120mA max.
 24VDC, 5%, 50mA max.
 Isolation (power gnd) Safety-rated to
 250VAC 4.2kVp per High Voltage Test

ORDERING INFORMATION 3-23-09

FREQUENCY, RATE, TOTAL AND TIME FUNCTIONS

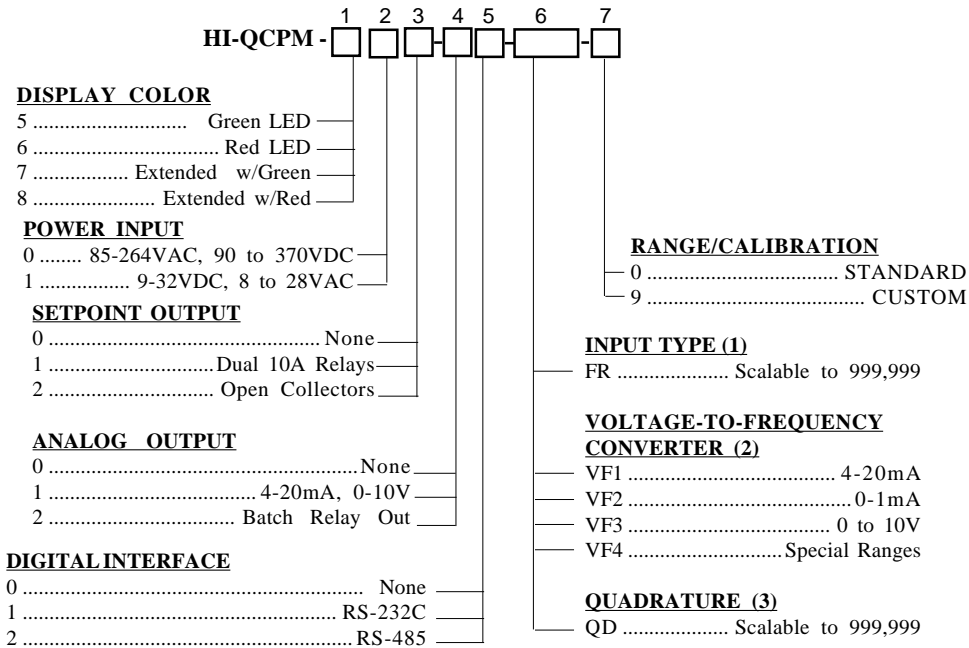

NOTES:

1. **Basic Counter:** Frequency, rate, total (up or down), period (2 channels simultaneously), time interval A to B, square root of rate.
Extended Counter: Above plus rate and total simultaneously, linearize non-linear inputs, ratio, draw, arithmetic functions (A*B, A/B, A+B, A-B), phase angle, stop watch, up/down counting, batch counting.
2. **Basic Counter:** Rate, square root of rate (differential pressure or target type flow meters).
Extended Counter: Above plus rate and total simultaneously, linerize non-linear inputs, batch counting, 1/rate (time).
3. **Basic Counter:** Position or length from encoders. Accepts differential or single-ended inputs, 1x, 2x or 4x inputs. Z channel (zero) input.