

# HI-QREM

## User's Manual

1-20-09



**O TEK** <sup>TM</sup>  
CORP.  
SINCE 1974

4016 E. Tennessee St.  
Tucson, AZ 85714-2130  
Tel: 520-748-7900  
Fax: 520-790-2808

# Mounting Instructions for the HI-QREM

## MOUNTING

PANEL CUTOUT

SIDE VIEW

MOUNTING INSTRUCTIONS:

- 1) INSTALL METER THROUGH PANEL CUTOUT.
- 2) INSTALL MOUNTING BRACKET OVER METER, WITH THE MOUNTING STUDS GOING THROUGH MOUNTING HOLES.
- 3) MOUNTING TABS SHOULD BE BETWEEN METER AND PANEL.
- 4) INSTALL LOCK WASHERS.
- 5) INSTALL NUTS AND TIGHTEN UNTIL FLUSH WITH PANEL.

REAR VIEW

REVISIONS				
ZONE	REV	DESCRIPTION	DATE	APPROVED
	A	INITIAL RELEASE	1/20/2009	NS

<p>UNLESS OTHERWISE SPECIFIED DIMENSIONS IN INCHES.</p> <p style="text-align: center;">-TOLERANCES-</p> <table style="width: 100%; border: none;"> <tr> <td style="border: none;">DECIMALS</td> <td style="border: none;">FRACTIONS</td> </tr> <tr> <td style="border: none;">.X = ±0.1</td> <td style="border: none;">±1/32</td> </tr> <tr> <td style="border: none;">.XX = ±0.01</td> <td style="border: none;">ANGLES ±2°</td> </tr> <tr> <td style="border: none;">.XXX = ±0.003</td> <td></td> </tr> </table>	DECIMALS	FRACTIONS	.X = ±0.1	±1/32	.XX = ±0.01	ANGLES ±2°	.XXX = ±0.003		<p>CONTRACT NO</p> <p>APP'D DRAWING</p> <p>APP'D DRAWING</p> <p>APP'D TAGGING</p> <p>APP'D SPECIALS</p>	<p><b>OTEK™ CORP.</b> SINCE 1974</p> <p>4016 E. Tennessee St. Tucson, AZ. 85714 WWW.OTEKCORP.COM</p> <table style="width: 100%; border: none;"> <tr> <td style="border: none;">SIZE</td> <td style="border: none;">FSCM NO.</td> <td style="border: none;">DWS NO.</td> <td style="border: none;">REV</td> </tr> <tr> <td style="border: none;">A</td> <td style="border: none;">57861</td> <td style="border: none;">86-NPM1</td> <td style="border: none;">A</td> </tr> <tr> <td style="border: none;">SCALE</td> <td colspan="2" style="border: none;">NONE</td> <td style="border: none;">SHEET 1 OF 1</td> </tr> </table>	SIZE	FSCM NO.	DWS NO.	REV	A	57861	86-NPM1	A	SCALE	NONE		SHEET 1 OF 1
DECIMALS	FRACTIONS																					
.X = ±0.1	±1/32																					
.XX = ±0.01	ANGLES ±2°																					
.XXX = ±0.003																						
SIZE	FSCM NO.	DWS NO.	REV																			
A	57861	86-NPM1	A																			
SCALE	NONE		SHEET 1 OF 1																			

# Electrical Connections for the HI-QREM

REAR VIEW

**TERMINAL DESCRIPTION**

1. + Power supply input for isolated 5, 12, 24 or 48VDC options.
2. Return for isolated power supply inputs.
3. +5VDC power input for non-isolated options or +5VDC output for isolated power options.
4. Intensity Control, connect to terminal 3 for normal operation.
5. Default Pin, connect to terminal 8 to force default mode.
6. RS485 "B" / RS232 TXD
7. RS485 "A" / RS232 RXD
8. RS485 / RS232 GROUND
9. USB +5V
10. USB GND
11. USB DATA -
12. USB DATA +

**NOTE:** For RS485 install a 120 ohm terminating resistor across pins 6 & 7 on the first & last units on the bus.

REVISIONS				
ZONE	REV	DESCRIPTION	DATE	APPROVED
	A	INITIAL RELEASE	1/20/2009	NS

<p>UNLESS OTHERWISE SPECIFIED DIMENSIONS IN INCHES.</p> <p style="text-align: center;">-TOLERANCES-</p> <table style="width: 100%; border: none;"> <tr> <td style="border: none;">DECIMALS</td> <td style="border: none;">FRACTIONS</td> </tr> <tr> <td style="border: none;">.X = ±0.1</td> <td style="border: none;">±1/32</td> </tr> <tr> <td style="border: none;">.XX = ±0.01</td> <td style="border: none;">ANGLES ±2°</td> </tr> <tr> <td style="border: none;">.XXX = ±0.003</td> <td></td> </tr> </table>	DECIMALS	FRACTIONS	.X = ±0.1	±1/32	.XX = ±0.01	ANGLES ±2°	.XXX = ±0.003		<p>CONTRACT NO</p> <p>APP'D DRAWING</p> <p>APP'D DRAWING</p> <p>APP'D TAGGING</p> <p>APP'D SPECIALS</p>	<p><b>OTEK™ CORP.</b> SINCE 1974</p> <p>4016 E. Tennessee St. Tucson, AZ. 85714 WWW.OTEKCORP.COM</p> <table style="width: 100%; border: none;"> <tr> <td style="border: none;">SIZE</td> <td style="border: none;">FSCM NO.</td> <td style="border: none;">DWS NO.</td> <td style="border: none;">REV</td> </tr> <tr> <td style="border: none;">A</td> <td style="border: none;">57861</td> <td style="border: none;">86-HI-QREM0</td> <td style="border: none;">B</td> </tr> <tr> <td style="border: none;">SCALE</td> <td colspan="2" style="border: none;">NONE</td> <td style="border: none;">SHEET 1 OF 1</td> </tr> </table>	SIZE	FSCM NO.	DWS NO.	REV	A	57861	86-HI-QREM0	B	SCALE	NONE		SHEET 1 OF 1
DECIMALS	FRACTIONS																					
.X = ±0.1	±1/32																					
.XX = ±0.01	ANGLES ±2°																					
.XXX = ±0.003																						
SIZE	FSCM NO.	DWS NO.	REV																			
A	57861	86-HI-QREM0	B																			
SCALE	NONE		SHEET 1 OF 1																			

# Serial Communications Protocol for the HI-QREM

## I. INTRODUCTION

The HI-QREM uses the standard OTEK communication protocol, ASCII S + <ADDRESS> + <COMMAND> + <CR>. The starting character is S followed by the address. The default address is 01. The command follows and must be terminated by a carriage return <CR>. This document applies to firmware release SL1\_R101.

## II. DEFAULT AND USER MODES

The HI-QREM has two modes of operation. In DEFAULT mode, the device uses factory set operating parameters defined in section IV. In USER mode, address, baud rate, configuration, flashing, and intensity settings revert to the state they were in the last time a WRITE command was issued. The run mode is determined on power-up by the connection of the default terminal. To enable the factory default settings, jumper terminals 5 & 8 together, then cycle power.

## III. DISPLAYED ASCII COMMAND SET

This table shows the hexadecimal ASCII number, the character for that number and the character as displayed on the HI-QREM digital display. Sending ASCII 8 ( BS - destructive backspace) will erase the previous character sent to the HI-QREM input buffer. Sending ASCII 27 (ESC) will clear the HI-QREM input buffer.

HEX	CHAR	DISPLAYED		HEX	CHAR	DISPLAYED
20		(SPACE)		47	G	<b>g</b>
2D	-	-		48	H	<b>H</b>
2E	.	.		49	I	<b>i</b>
2F	/	-		4A	J	<b>J</b>
30	0	<b>0</b>		4B	K	-
31	1	<b>1</b>		4C	L	<b>L</b>
32	2	<b>2</b>		4D	M	-
33	3	<b>3</b>		4E	N	<b>n</b>
34	4	<b>4</b>		4F	□	<b>o</b>
35	5	<b>5</b>		50	P	<b>P</b>
36	6	<b>6</b>		51	Q	-
37	7	<b>7</b>		52	R	<b>r</b>
38	8	<b>8</b>		53	S	<b>S</b>
39	9	<b>9</b>		54	T	<b>t</b>
41	A	<b>A</b>		55	U	<b>U</b>
42	B	<b>b</b>		56	V	-
43	C	<b>c</b>		57	W	-
44	D	<b>d</b>		58	X	-
45	E	<b>E</b>		59	Y	<b>y</b>
46	F	<b>F</b>		5A	Z	-

#### IV. COMMANDS

COMMAND	DESCRIPTION	RANGE	EXAMPLE
ADDRn	Changes the address. Default is 01.	n = 0 to 2 ASCII characters.	S01ADDR99<CR>
BAUDnn	Changes the baud rate. Default is 9600.	nn = 12 ⇒ 1200 baud. nn = 24 ⇒ 2400. nn = 48 ⇒ 4800. nn = 96 ⇒ 9600.	S01BAUD2400<CR>
Dnn	Displays ASCII characters on 7 segment display. See also section II.	nn= ASCII chars.	S01DHI<CR> display shows HI
FLASHn	Flashes display Default is 0.	n = 0 to 1 no flashing. n = 2 to 3 slowest (1.14 S). n = 4 to 5 slow. n = 6 to 7 medium. n = 8 to 9 fastest (142 mS).	S01FLASH0<CR> S01FLASH3<CR>
INTn	Change display Intensity. There are four levels. Default is 9.	n = 0 off. n = 1 to 3 dim. n = 4 to 6 medium. n = 7 to 9 brightest.	S01INT0<CR> display off S01INT9<CR> display max
PTn	Light decimal point position. Default is 0.	n = 0 no decimals on. n = 1 to 2, numbered from left of the display.	S01PT1<CR> 1st decimal point on.
RST	Resets HI-QREM to user values held in EEPROM.	N/A	S01RST<CR>
WRITE	Saves configuration data to EEPROM. Data saved includes: ADDR, BAUD, FLASH and INT	N/A	S01WRITE<CR>

# Mechanical Information for the HI-QREM Housing

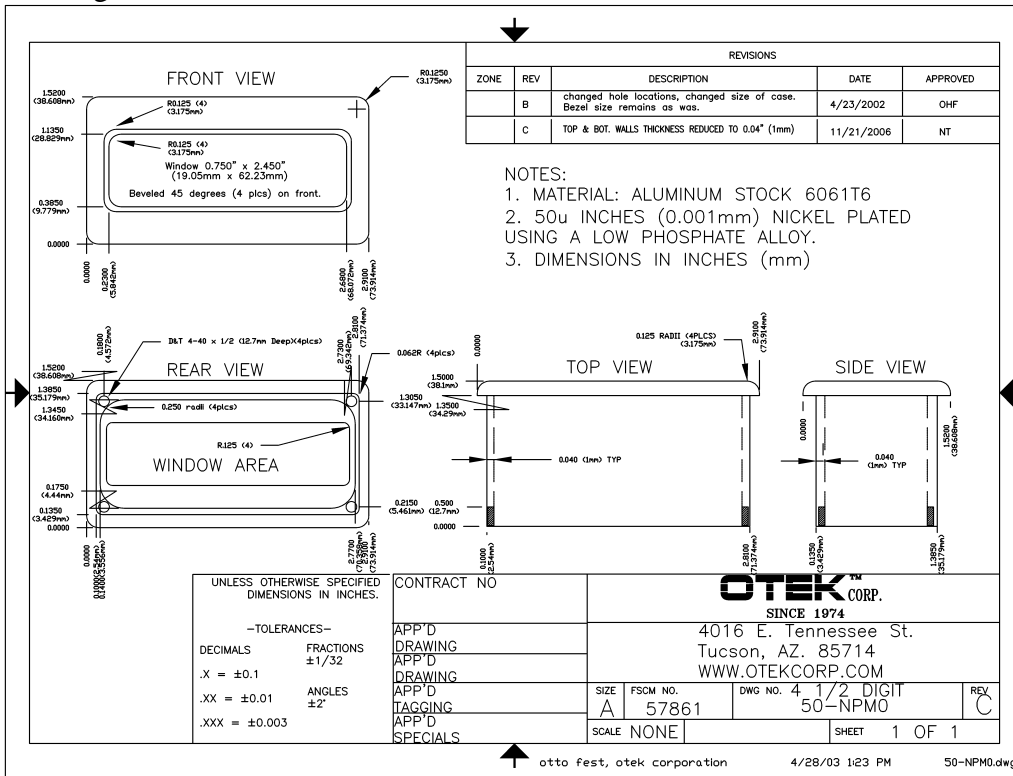

# Back Plate

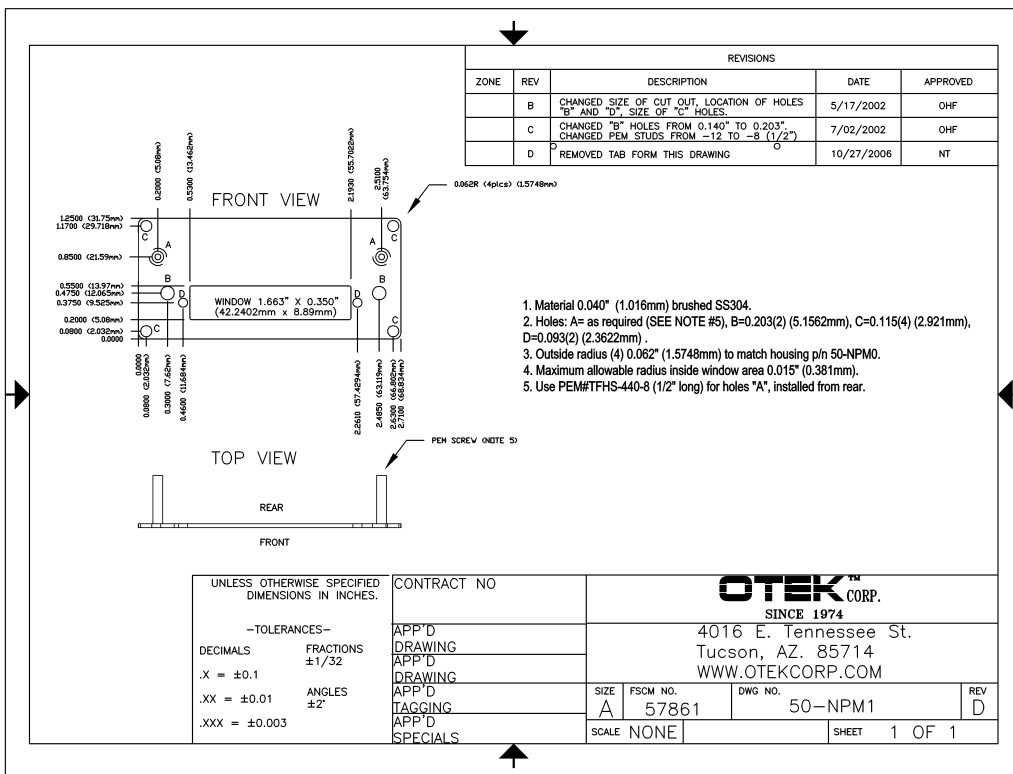

# Mechanical Information for the HI-QREM CONT. Mounting Bracket

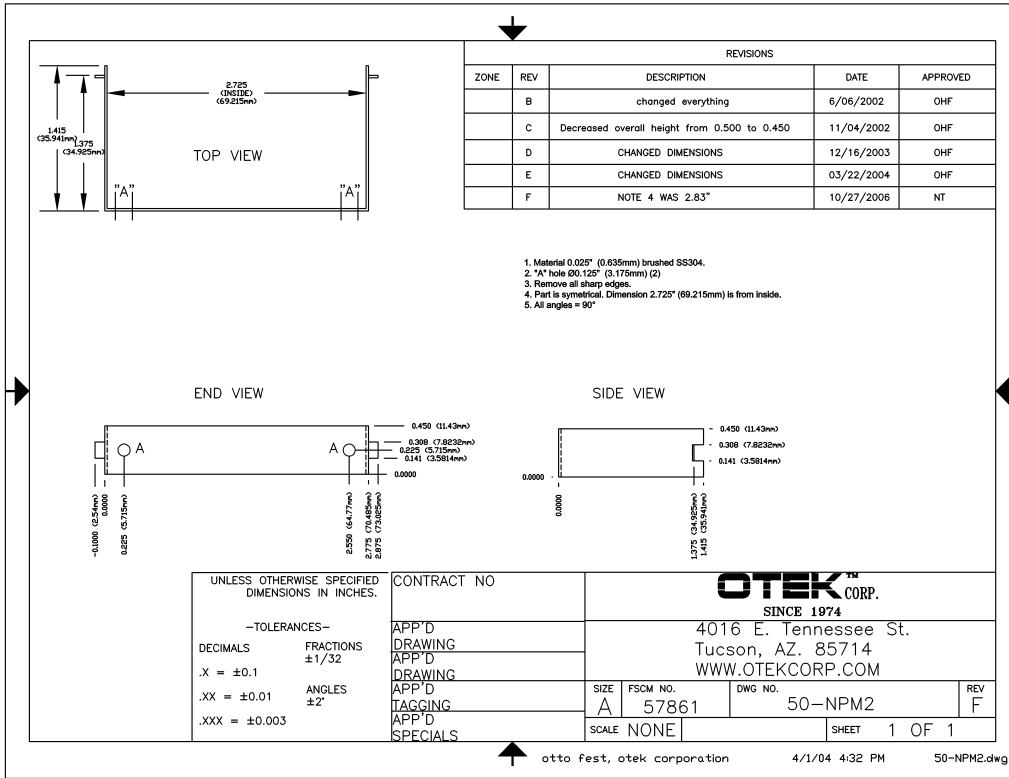

## SANITARY CASE

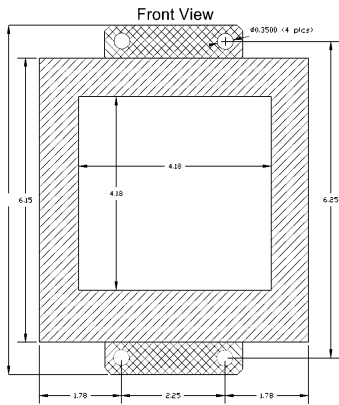

## Side View

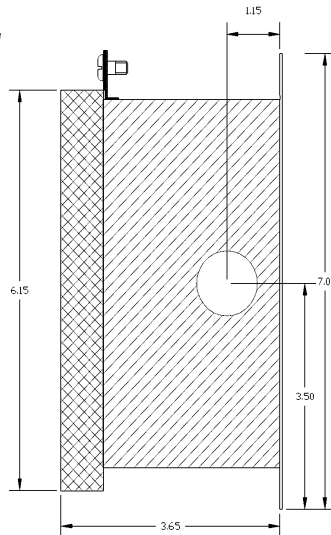

## EXPLOSION PROOF

