

# Low Cost Smart Bargraph-Digital Meters

For V/mADC Input And/Or RS-232C/485, Remote Displays

**MODEL  
HI-QSLIM**

HI-QSLIM1



8 DIGITS  
7 SEGMENTS

Zero & Span Adjustments Behind Overlay Not Shown

HI-QSLIM3 Horizontal Version  
(Center Zero Available)



HI-QSLIM2

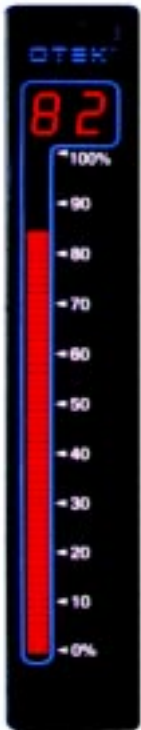

**DESCRIPTION:**

O TEK's new **HI-QSLIM** series of Low Cost Smart Indicators complement the extensive and proven HI-Q line of **Intelligent Programmable Controllers**. We have applied our expertise to bring you the industry's first low cost bargraph, without sacrificing the quality and reputation of our HI-Q line.

**The HI-QSLIM1** offers eight (8) digits, seven-segment 0.6" display with limited alpha characters and 0-9 numerals plus decimal points. **The HI-QSLIM2** has 51 segments (2% resolution & 2 digits(1%)).

**The HI-QSLIM3** gives you 1% resolution with its 101 segment high intensity bargraph & 2 digit displays.

**Whichever** you choose for your application, you can depend on its quality and OTEK's limited lifetime warranty.

**FEATURES:**

- RS-232C or RS-485 I/O
- ASCII Characters
- Stackable in 1 Inch Centers
- Vertical or Horizontal Viewing
- Zero & Span Front Panel Controls
- Only 2" Deep NEMA4 Housing 6x1x2"
- 5VDC, Isolated 10-32VDC or 90-265VAC Power Input
- Standard Unicolor Red or Custom Multicolor (R,G,Y)
- Free Custom Software for Minimum Purchases
- Compatible with Any RS-232/422/485 ASCII System
- Polycarbonate Overlay

HI-QSLIM3



**APPLICATIONS:** (See Note 2)

- Remote Display for RS-232/485
- Process Meter (4-20mA/0-5VDC)
- Trend Indicator
- Counter
- Timer
- Inclinometer Indicator
- Well Depth
- Distance
- Position
- Altitude
- Temperature
- Pressure
- Flow
- Humidity
- pH
- RPM
- Strokes Per Hour/Per Minute

**ORDERING INFORMATION (10-02-07)**

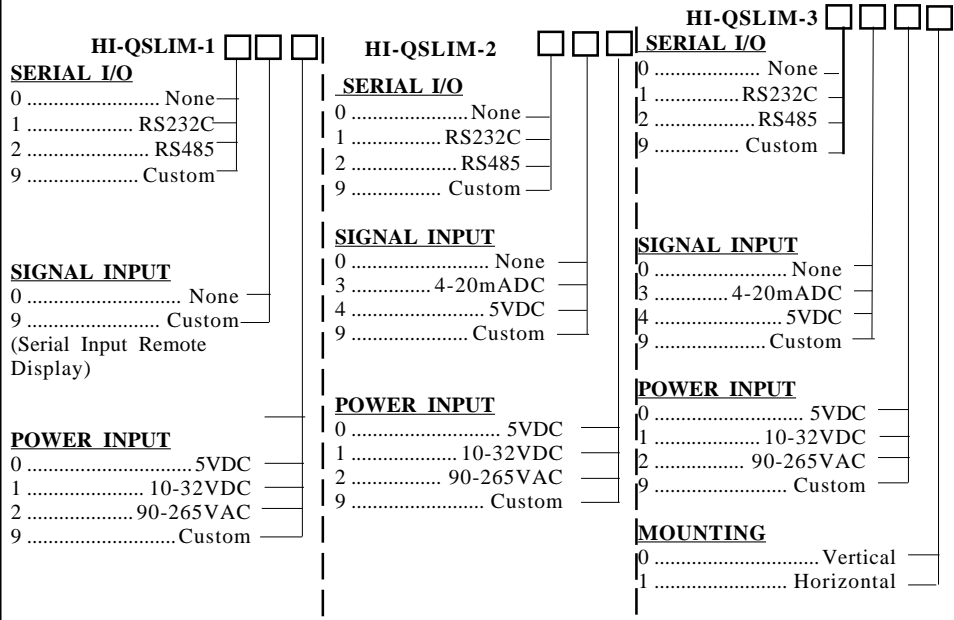

60% of ACTUAL SIZE

2 DIGITS & 51 SEGMENTS

60% of ACTUAL SIZE

2 DIGITS & 101 SEGMENTS

### MECHANICAL INFORMATION

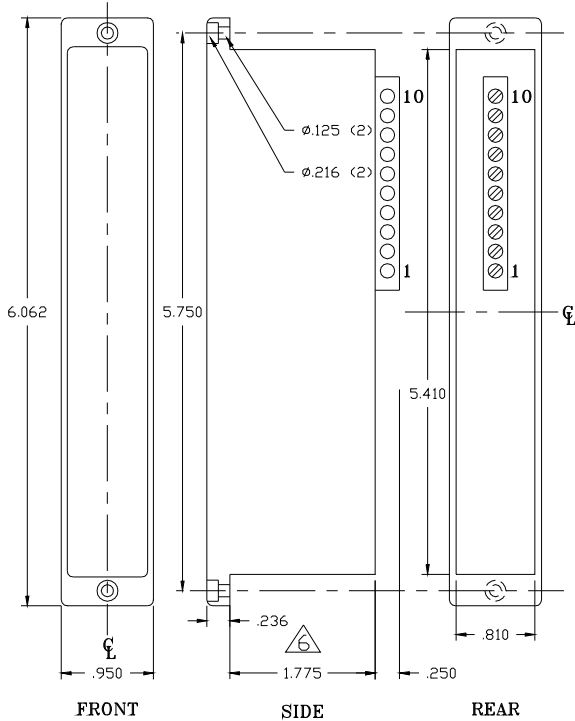

- NOTES:  
 1. RECOMMENDED PANEL CUTOUT: 0.840 x 5.452  
 2. MOUNTING HOLES (2) FOR #4 CLEARANCE  
 3. WIRE SIZE ACCEPTED > 24 < 16 GA.  
 4. ALL DIM ±0.010"  
 5. FOR STACKED APPLICATIONS MAKE MOUNTING HOLES ON 0.960" CENTERS.  
 6. UNITS W/O POWER SUPPLY ARE ONLY 1.00" DEEP

F# 87SLIMME

### TYPICAL CONNECTIONS (All Models)

- Notes: 1. Refer to your specific model# before making connections  
 2. Always apply power before signal  
 3. 5VDC ±5% (0.25V) at connector  
 4. Notice terminal orientation before connecting

Terminal #	Description	Notes
10	Dig. Gnd.	RS-232C & Digital Signal Ground
9	Int 0	Do Not Connect Reserved for Custom
8	T 0	Default Control
7	RXD/DO	Receive Data (RS-232C/485)
6	TXD/DO	Transmit Data (RS-232C/485)
5	Hi Pulse In	+Digital Signal Input or Contact
4	+Signal In	+Analog Signal Input
3	-Signal In or Low Pulse In	Internal Instrument Ground for Analog Inputs
2	+Power In	+For VDC or AC High Input
1	-Power In	Gnd. for VDC or AC Low Power In

### SPECIFICATIONS

PARAMETER	HI-QSLIM-1	HI-QSLIM-2	HI-QSLIM-3
# Segments	None	51	101
# Digits	Eight (8)	Two (2)	Two (2)
Analog Input Accuracy		±1%	±0.1%
Analog Input Resolution		1% (1 in 100)	±1% (1 in 100)
Polarity		Unipolar	Unipolar
Zero & Span		Yes	Yes
Input Impedance mA/VDC		200Ω/100KΩ	200Ω/100KΩ
Digital Input		TTL/CMOS	TTL/CMOS
Multilevel Inputs		Dry Contact to 250V	Dry Contact to 250V
Frequency Response TTL		10K Hz	10KHz
Serial I/O	RS-232C/RS485	RS-232C/RS485	RS-232C/RS485
Characters	ASCII	ASCII	ASCII
Baud Rate	9600 Std.	9600 Std.	9600 Std.
Address Selection	Via Serial Port	Via Serial Port	Via Serial Port
Power Req't @5VDC	2W	2W	2W
Power Input Non-isolated	5VDC±5%	5VDC±5%	5VDC±5%
Power Input Isolated	10-32VDC (or 24VAC)	10-32VDC(or 24VAC)	10-32VDC (or 24VAC)
Power Input Isolated	90-265VAC	90-265VAC	90-265VAC
Operating Temperature	0-60°C	0-60°C	0-60°C
Storage Temperature	-20 to 70°C	-20 to 70°C	-20 to 70°C
Humidity	5-95% N.C.	5-95% N.C.	5-95% N.C.
MTBF (Calculated)	100,000Hrs	100,000Hrs	100,000Hrs
Front Panel	NEMA 4	NEMA 4	NEMA 4
Weight	3 oz. (84g.)	3 oz. (84g.)	3 oz. (84g.)

\* Specifications Subject to Change Without Notice! Contact OTEK for Your Custom Needs!!

520-748-7900

FAX: 520-790-2808

E-MAIL:sales@otekcorp.com

http://www.otekcorp.com

**OTEK**™  
CORP.

SINCE 1974

4016 E. TENNESSEE ST.  
TUCSON, AZ. 85714 U.S.A.

MADE  
IN  
USA





SINCE 1974

4016 E. Tennessee St.  
Tucson, AZ 85714-2130  
Tel: 520-748-7900  
Fax: 520-790-2808

## Operation Guide for HI-QSLIM2™ Analog and Remote Bargraph-Digital Meter

### I. INTRODUCTION

The HI-QSLIM2 has a two digit seven segment LED display and a 51 element LED bargraph display. The user can configure the HI-QSLIM2's response to serial input, analog input and display formatting. HI-QSLIM2 ordering options include serial input/outputs, analog input signal processing and power supply. Sections of this document apply to specific hardware configurations the user may not have ordered. For example, analog input readings are not available if Signal Input option -0 (none) is specified. This document applies to firmware release SL2\_A200.

### II. ANALOG CALIBRATION

If ordered with the appropriate options, the HI-QSLIM2 measures an analog input and displays the measurement on the digital and bar graph display and sends it over the serial communication link.

#### Analog to Digital Converter

The input voltage or current to the HI-QSLIM2's Analog to Digital (A/D) must be positive in reference to signal ground. The input measurement from the A/D converter ranges from 0 to 4095 counts. Sixteen readings are added together for a sum ranging from 0 to 65,535 counts. The HI-QSLIM2 makes approximately 225 summed readings per second. An A/D reading from 65,021 to 65,535 counts causes an over-range condition; the digital display will show *or* and the bargraph will flash. From 0 to 65,021 A/D counts, readings are processed and displayed. These values are fixed in the HI-QSLIM2's programming.

#### Zero and Span Adjustments

The zero and span potentiometers, behind the HI-QSLIM2 front cover overlay, adjust the input signal range over which the A/D is making its conversions. The zero potentiometer sets the bottom limit of A/D conversions. For example, the zero potentiometer makes the HI-QSLIM2 A/D start converting input signals in a 4 to 20 mA loop at 4 mA. The span potentiometer sets the full scale range of the A/D. In the 4 to 20 mA loop example, the span potentiometer is set to produce an over-range condition just above 20 mA. This makes 20 mA the full scale reading and provides the best A/D accuracy.

#### Scale and Offset

The input measurement actually displayed on the HI-QSLIM2 digital and bargraph display can be calibrated to show engineering units by scaling and offsetting the raw A/D values. For example, an A/D reading of 65,000 could be scaled to show 20 on the digital display (representing 20 mA or 20 PSI). This same A/D reading could also be scaled to light all the bar graph LEDs (representing 100% of full scale).

There are two separate scale and offset values used in the HI-QSLIM2. One set works on the A/D data displayed on the digital display and sent to the serial communication port. The other scale and offset are used for the bargraph. Section IX describes the commands for setting both sets of scales and offsets.

#### Factory Settings

## Operation Guide for HI-QSLIM2™ Analog and Remote Bargraph-Digital Meter

Best results are obtained from the HI-QSLIM2 when the zero and span hardware adjustments are used to set the optimum A/D input range for a given input signal. The scale and offset are then used to tailor the displays for specific engineering units. HI-QSLIM2s are calibrated at the factory for the ordered input signal range using the zero and span adjustments. The scale and offset values are set to display 0 to 99% on the digital and bargraph display for that input range. These scale and offset values are the default values (see section VII). These are also stored as the user values unless the customer requests special scales and offsets.

### Scale and Offset Calculations :

All scale and offsets must be rounded to the nearest integer value. The general formula for displays is :

$$\text{Display value} = (\text{A/D reading} / \text{Scale}) + \text{Offset}$$

$$\text{Display value} = \text{digital display numerals or number of bargraph LEDs on.}$$

$$\text{Full scale digital display scale} = 65,021 / (\text{Desired digital display} + 0.5)$$

$$\text{Example: Scale} = 65,021 / (99 + 0.5) = 653 \text{ (default digital display scale)}$$

$$\text{Digital display offset} = 0 \text{ (default digital display offset)}$$

$$\text{Full scale bargraph scale} = 65,021 / (\text{Number of bars to light} + 0.5)$$

$$\text{Example: BarScale} = 65,021 / (49 + 0.5) = 1313 \text{ (default bargraph scale)}$$

Bargraph offset = 1 (default digital display scale) Note: LED 1 is typically set *on* to represent the zeroth LED.

### III. REMOTE DISPLAY

If a serial I/O option is ordered, the HI-QSLIM2 can also be configured as a remote display. In this mode serial data sent to the HI-QSLIM2 will be displayed. The serial data is treated as if it were an A/D value. The same two sets of scale and offset values act upon the serial input data. See section III above for information on setting the scales and offsets. A HI-QSLIM2 with an analog signal input option can be used as a remote display if the A/D converter is turned off by the CONF command (see section IX for a table of HI-QSLIM2 commands).

### IV. SERIAL COMMUNICATION

The HI-QSLIM2 uses the standard OTEK serial communication protocol, ASCII S + <ADDRESS> + <COMMAND> + <CR>. The starting character is S followed by the address. The default address is 01. The command follows and must be terminated by a carriage return <CR>.

When a HI-QSLIM2 receives a valid 'S' + address sequence, it tries to interpret the characters following as a command. If so configured, the HI-QSLIM2 will respond with an asterisk (\*) for a valid command and a question mark (?) for a command it wasn't able to decode. See section IX for a table of HI-QSLIM2 commands.



# Operation Guide for HI-QSLIM2™ Analog and Remote Bargraph-Digital Meter

## VI. SAMPLE HI-QSLIM2 OPERATING MODES

Samples in this section apply to specific hardware configurations the user may not have ordered. For example, to set the following sample operating modes, a serial I/O option must have been ordered. To use the HI-QSLIM2 as an analog input meter, a signal input option must be ordered for the HI-QSLIM2.

### RS-232 Remote Digital Display with Bottom Zero Bargraph Display.

In this mode, the HI-QSLIM2 displays data sent from a host computer. All serial commands sent to the HI-QSLIM2 are echoed back. The bar graph display follows the digital display. This means a number sent to the digital display is displayed on the bargraph display also. Both displays are scaled for 0 to 100%. If the host computer sends the number 50 (ASCII 53 + ASCII 48), the digital display shows **50** and 50% of the bar graph elements light. The CONF values and a serial command sequence to set the scales and offsets are shown below.

Bit Value	1 <sup>st</sup> Digit Function	1 <sup>st</sup> Digit Value	2 <sup>nd</sup> Digit Function	2 <sup>nd</sup> Digit Value
1	Bar graph mode select bit 0	0	Enable readings	0
2	Bar graph mode select bit 0	0	Enable serial transmission of readings.	0
4	Enables bargraph follows digital display.	1	Enable echo serial inputs.	1
8	Enables calibration mode.	0	Enables RS-485 Mode.	0
	First Digit Total =	<b>4</b>	Second Digit Total =	<b>4</b>

Table 3. RS-232 Remote Digital Display with Bottom Zero Bargraph Display CONF Value.

S01CONF44<CR>	Set configuration.
S01S1<CR>	Set the digital display scale.
S01O0<CR>	Set the digital display offset.
S01BS2<CR>	Set the bargraph scale.
S01BO1<CR>	Set the bargraph offset.
S01WRITE<CR>	Save values to user's memory.
S01D50<CR>	Display 50 and 50%..

# Operation Guide for HI-QSLIM2™ Analog and Remote Bargraph-Digital Meter

## RS-485 Remote Digital Display with Bottom Zero Bargraph Display.

Same as example above, but on a RS-485 system that does not want any echoes or responses from the HI-QSLIM2.

Bit Value	1 <sup>st</sup> Digit Function	1 <sup>st</sup> Digit Value	2 <sup>nd</sup> Digit Function	2 <sup>nd</sup> Digit Value
1	Bar graph mode select bit 0	0	Enable readings	0
2	Bar graph mode select bit 0	0	Enable serial transmission of readings.	0
4	Enables bargraph follows digital display.	1	Enable echo serial inputs.	0
8	Enables calibration mode.	0	Enables RS-485 Mode.	1
	First Digit Total =	<b>4</b>	Second Digit Total =	<b>8</b>

Table 4. RS-485 Remote Digital Display with Bottom Zero Bargraph Display CONF Value.

S01CONF48<CR> Set configuration.  
 S01S1<CR> Set the digital display scale.  
 S01O0<CR> Set the digital display offset.  
 S01BS2<CR> Set the bargraph scale.  
 S01BO1<CR> Set the bargraph offset.  
 S01WRITE<CR> Save values to user's memory.  
 S01D50<CR> Display 50 and 50%..

## RS-232 Analog Input Meter with Zero Bottom Bargraph

This is the factory default mode. Digital display shows 0 to 99, bargraph displays 1 LED on at zero input and all LEDs on at full scale. Echo of RS-232 input and HI-QSLIM2 responses enabled.

Bit Value	1 <sup>st</sup> Digit Function	1 <sup>st</sup> Digit Value	2 <sup>nd</sup> Digit Function	2 <sup>nd</sup> Digit Value
1	Bar graph mode select bit 0	0	Enable readings	1
2	Bar graph mode select bit 0	0	Enable serial transmission of readings.	0
4	Enables bargraph follows digital display.	0	Enable echo serial inputs.	1
8	Enables calibration mode.	0	Enables RS-485 Mode.	0
	First Digit Total =	<b>0</b>	Second Digit Total =	<b>5</b>

Table 5. RS-232 Analog Input Meter with Zero Bargraph CONF Value

S01CONF5CR> Set configuration.  
 S01S653<CR> Set the digital display scale.  
 S01O0<CR> Set the digital display offset.  
 S01BS1313<CR> Set the bargraph scale.  
 S01BO1<CR> Set the bargraph offset.  
 S01WRITE<CR> Save values to user's memory.

# Operation Guide for HI-QSLIM2™ Analog and Remote Bargraph-Digital Meter

## RS-232 Analog Input Meter with Zero Bottom Moving Dot Graph

Same example as above, but the solid bar LED graph is replaced with a moving dot.

Bit Value	1 <sup>st</sup> Digit Function	1 <sup>st</sup> Digit Value	2 <sup>nd</sup> Digit Function	2 <sup>nd</sup> Digit Value
1	Bar graph mode select bit 0	1	Enable readings	1
2	Bar graph mode select bit 0	1	Enable serial transmission of readings.	0
4	Enables bargraph follows digital display.	0	Enable echo serial inputs.	1
8	Enables calibration mode.	0	Enables RS-485 Mode.	0
	First Digit Total =	3	Second Digit Total =	5

Table 6. RS-232 Analog Input Meter with Zero Bottom Moving Dot Graph CONF Value

S01CONF35CR> Set configuration.  
 S01S653<CR> Set the digital display scale.  
 S01O0<CR> Set the digital display offset.  
 S01BS1313<CR> Set the bargraph scale.  
 S01BO1<CR> Set the bargraph offset.  
 S01WRITE<CR> Save values to user's memory.

## RS-232 Analog Input Meter with Center Zero Bar Graph and Continuous RS-232 Reading Transmission

HI-QSLIM2 reads analog input and displays as 0 to 99 on digital display. Bargraph is configured for a center zero when the input is 50% of full scale. Readings below 50% of full scale will light bargraph elements below the center of the graph, inputs above 50% will light LEDs above the center of the bargraph. Note if the digital display is also offset with a "S01O-50" command the negative sign will occupy the leftmost of the two digital display places. e.g. -50 is displayed as -5.

Bit Place	Bit Value	1 <sup>st</sup> Digit Function	1 <sup>st</sup> Digit Value	2 <sup>nd</sup> Digit Function	2 <sup>nd</sup> Digit Value
1	1	Bar graph mode select bit 0	0	Enable readings	1
2	2	Bar graph mode select bit 0	1	Enable serial transmission of readings.	1
3	4	Enables bargraph follows digital display.	0	Enable echo serial inputs.	1
4	8	Enables calibration mode.	0	Enables RS-485 Mode.	0
		First Digit Total =	2	Second Digit Total =	7

Table 8. RS-232 Analog Input Meter with Center Zero Bar Graph and Continuous RS-232 Reading Transmission CONF Value.

S01CONF27CR> Set configuration.  
 S01S653<CR> Set the digital display scale.  
 S01O0<CR> Set the digital display offset.  
 S01BS1313<CR> Set the bargraph scale.  
 S01BO-24<CR> Set the bargraph offset.  
 S01WRITE<CR> Save values to user's memory.



SINCE 1974

4016 E. Tennessee St.  
 Tucson, AZ 85714-2130  
 Tel: 520-748-7900  
 Fax: 520-790-2808

## Serial Communications Protocol for the HIQ-SLIM 2 and SLIM 3 Remote Display (7-06)

### I. INTRODUCTION

The SLIM 2 and SLIM 3 uses the standard OTEK communication protocol, ASCII S + <ADDRESS> + <COMMAND> + <CR>. The starting character is S followed by the address. The default address is 01. The command follows and must be terminated by a carriage return <CR>. This document applies to firmware release SL2\_R100 and SL3\_R100.

### II. BARGRAPH FOLLOWS DIGITAL MODE

The seven segment digital display is controlled using the “d” command. Sending S01D45 displays 45 on the seven segment display. The BR. and BR\* command sends data for the bargraph display. The serial string S01BR.45 will illuminate 45% of the bottom LED bargraph segments.

### III. DEFAULT AND USER MODES

The SLIM 2 and SLIM 3 have two modes of operation. In DEFAULT mode, the device uses factory set operating parameters defined in section V. In USER mode, address, baud rate, configuration, flashing, and intensity settings revert to the state they were in the last time a WRITE command was issued. Which mode is used is determined on powerup by the position of an external jumper. To enable the factory default settings, jumper terminals 1 and 8 together. Serial commands can also change the operating modes (RST, RST/C).

### IV. DISPLAYED ASCII COMMAND SET

This table shows the decimal ASCII number, the character for that number and the character as displayed on the SLIM 2 AND 3 digital display. Sending ASCII 8 ( BS - destructive backspace) will erase the previous character sent to the SLIM 2 AND 3 input buffer. Sending ASCII 27 (ESC) will clear the SLIM 2 AND 3 input buffer.

<u>Decimal</u>	<u>Char.</u>	<u>Display</u>	<u>Decimal</u>	<u>Char.</u>	<u>Display</u>	<u>Decimal</u>	<u>Char.</u>	<u>Display</u>	<u>Decimal</u>	<u>Char.</u>	<u>Display</u>
45	-	-	56	8	8	67	C	c	79	O	o
46	.	.	57	9	9	68	D	d	80	P	P
47	/	_	58	:	_	69	E	E	81	Q	_
48	0	0	59	;	_	70	F	F	82	R	r
49	1	1	60	<	_	71	G	g	83	S	S
50	2	2	61	=	=	72	H	h	84	T	t
51	3	3	62	>	_	73	I	i	85	U	U
52	4	4	63	?	_	74	J	J	86	V	_
53	5	5	64	'	_	75	K	_	87	W	_
54	6	6	65	A	A	76	L	L	88	X	_
55	7	7	66	B	b	77	M	_	89	Y	Y
						78	N	n	90	Z	_

## V. COMMANDS

COMMAND	DESCRIPTION	RANGE	EXAMPLE
ADDRn	Changes the address. Default is 01.	n = 0 to 2 ASCII characters.	S01ADDR99<CR>
BAUDnn	Changes the baud rate. Default is 9600.	nn = 12 ? 1200 baud. nn = 24 ? 2400. nn = 48 ? 4800. nn = 96 ? 9600.	S01BAUD2400<CR>
BR.nn	Illuminates nn % of the bars from the bottom of the bargraph.	nn = 0 to 100. Non-numeric data is ignored. Only integer values are displayed.	S01BR.45<CR> 45% of the bottom bars are illuminated.  S01BR.4.5<CR> 4% of the bottom bars are illuminated
BR*nn	Illuminates nn % of the bars from the top of the bargraph.	nn = 0 to 100. Non-numeric data is ignored. Only integer values are displayed.	S01BR* +/-45<CR> 45% of the top bars are illuminated.
CONFn	Change the SLIM configuration. Default is 4.	n = (return). Returns current config. 0 = no echo of serial input. 4 = echo serial inputs.	S01CONF<CR> Shows current configuration.
Dnn	Displays ASCII characters on 7 segment display. See also section II.	nn= ASCII chars.	S01DHI<CR> display shows HI
FLASHn	Flashes display	n = 0 to 1 no flashing. n = 2 to 3 slowest (1.14 S). n = 4 to 5 slow. n = 6 to 7 medium. n = 8 to 9 fastest (142 mS).	S01FLASH0<CR> S01FLASH3<CR>
INTn	Change display Intensity. There are four levels. Default is 9.	n = 0 off. n = 1 to 3 dim. n = 4 to 6 medium. n = 7 to 9 brightest.	S01INT0<CR> display off S01INT9<CR> display max
PTn	Light decimal point position. Default is 0.	n = 0 no decimals on. n = 1 to 2, numbered from left of the display.	S01PT1<CR> 1st decimal point on.
RST	Resets SLIM to user values held in EEPROM.	N/A	S01RST<CR>
RST/C	Resets SLIM to factory default values.	N/A	S01RST/C<CR>
WRITE	Saves configuration data to EEPROM. Data saved includes: D+B mode, ADDR, BAUD, CONF, FLASH and INT	N/A	S01WRITE<CR>