

**RTD TEMPERATURE 3½ DIGIT LED DPM
"Flat Pack" No Panel Cut Out Required
(NEMA 3 or NEMA 4X)**

**MODEL
526**

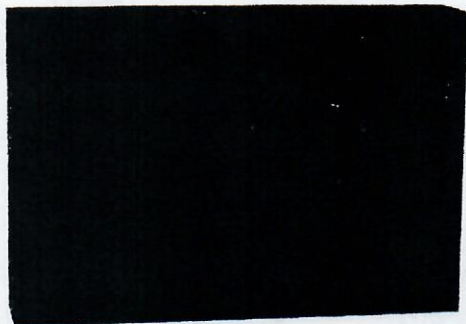

FLAT PACK

Features

- Only ½" Deep
- Built-in Open RTD Alarm
- 2 or 3 Wire RTD
- Automatic Lead Compensation
- 0.6" Bright LED
- °F or °C and PT100, ASA or 10Ω Copper
- Analog Output
- MTBFC: 100,000 Hours



SANITARY

DESCRIPTION: Model 526 is offered in our unique Flat Pack housing (see housing description below).

Alpha of 0.00385Ω/Ω/°C (DIN); 0.003923Ω/Ω/°C (ANSI) or 10 Ohm copper elements are accurately conditioned for reliable temperature measurement. An analog comparator is included that indicates an open RTD sensor condition by -1 on the display.

Zero and Span adjustments allow the 526 to be calibrated to other than engineering units such as percentage.

HOUSING: Otek's Flat Pack requires no panel cut out. Just drill a 10mm (3/8") Ø hole, pass the wires through, attach the provided double-sided tape (to prevent rotation), align the flat pack, tighten the nut and make the connections to the wires. No connector or tools required! No behind the panel space needed! The case is U.L. approved ABS Polycarbonate 94VO rated. **NEMA 4X housing option does not have access to the adjustments. If other than Otek's standard setting is required, please specify at the time of ordering.** Our New Sanitary housing is wall, pipe or panel mount and can include 2 flat packs, please specify.

POWER SUPPLIES: Externally mounted. Two types are available, the "Open Frame" style accepts 120/240VAC and delivers 5VDC up to 400mADC. The "Power Pack" is a wall plug in module available only for 120VAC input and delivers 5VDC at up to 200mADC.

ORDERING INFORMATION (11/100)

MODEL 5 2 6 - - - 0	
INPUT RANGE	POWER INPUT(2)
0 200.0°C DIN	0 5VDC
1 2000°C DIN	1 Open Frame 120/240VAC
2 200.0°F DIN	2 Power Pack 120VAC
3 2000°F DIN	HOUSING (1)
4 20.0°C ANSI	0 NEMA 3
5 2000°C ANSI	1 NEMA 4X
6 200.0°F ANSI	2 Sanitary
7 2000°F ANSI	(1) See NEMA 4X note in "Housing"
8 200.0°C Copper	section above
9 200.0°F Copper	(2) See "Power Supplies" section above

RTD TEMPERATURE RANGE GOVERNS THE INSTRUMENT RANGE.

SPECIFICATIONS AT 25°C

Drift vs Temperature	50 PPM/°C
Accuracy and Linearity	±1% ±1 Count
Input Type	2 or 3 Wire RTD
CMV	±3VDC
CMRR	90dB
Input Protection	±5VDC
Power Requirements	5VDC at 180mA
Operating/Storage Temp.....	-10° to +60°C/-20° to +70°C
Display Type	3½ Digit 0.6" Red LED
Maximum Excitation Current	1mA
Lead Resistance Compensation	20 OHMS
MTBFC	100,000 Hours
Sanitary Case	NEMA 4X up to 250°F Steam Cleaning

**LEAD
COLOR**

TERMINAL DESCRIPTION

YELLOW	+IN: The most positive side of the RTD,(White).
RED	+5VDC IN: Connect a +5VDC ±10% power supply with a 180 mA source capability.
WHITE	-INPUT: Connect to the most negative side of the RTD (Red) to this lead.
BLACK	GROUND: Return for ±5VDC; Use this ground to enable decimal points.
GREEN	SIGNAL COMMON: Connect to compensating Red lead of RTD for 3 wire or to White lead for 2 wire RTD.
BLUE	ANALOG OUT: »1mV/count, 0.1 mA MAX, reference to Green.
VIOLET	DECIMAL POINT 1.XXX: This decimal point will illuminate when connected to Black.
GRAY	DECIMAL POINT 1X.XX: This decimal point will illuminate when connected to Black.
BROWN	DECIMAL POINT 1XX.X: This decimal point will illuminate when connected to Black.
ORANGE	DECIMAL POINT 1XXX.: This decimal point will illuminate when connected to Black.

NOTE: For 3 wire RTD : Connect one Red to Green, the other Red to White.
For 2 wire RTD : Jumper White and Green and connect RTD's Red to them.

TEMPERATURE RTD

526 FLAT PACK MECHANICALS & TYPICAL CONNECTIONS

FLAT PACK W/WIRES

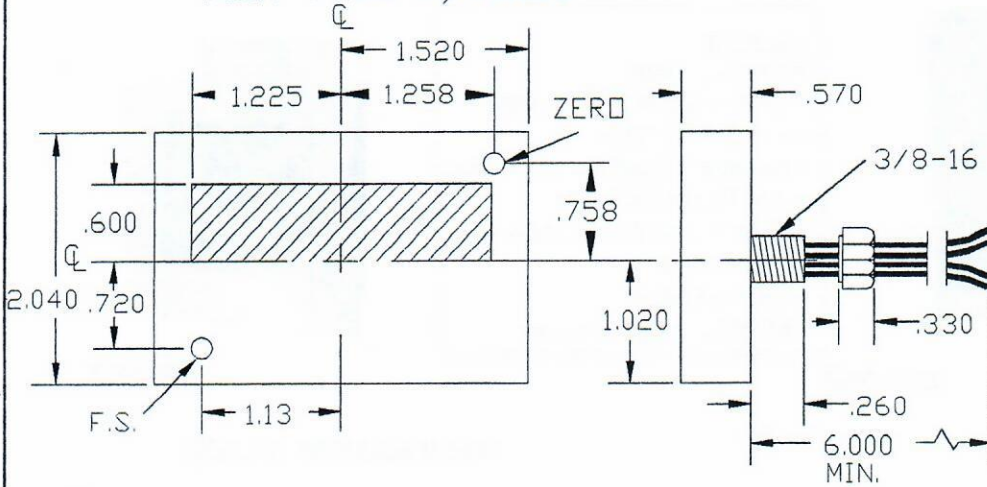

SANITARY CASE

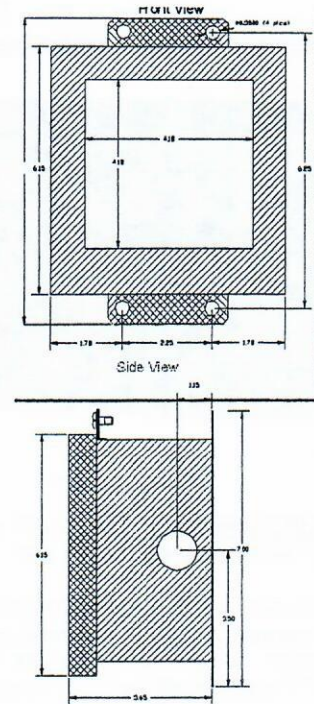

MECHANICALS FOR POWER SUPPLIES

OPEN FRAME STYLE
P/N 81-3110, 5VDC OUTPUT
P/N 81-3113, 24VDC OUTPUT

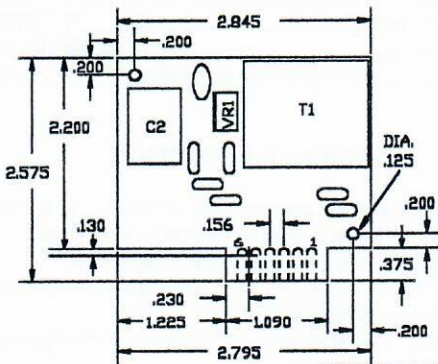

SIDE VIEW

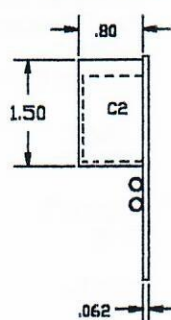

OPEN FRAME POWER SUPPLY
TYPICAL CONNECTIONS

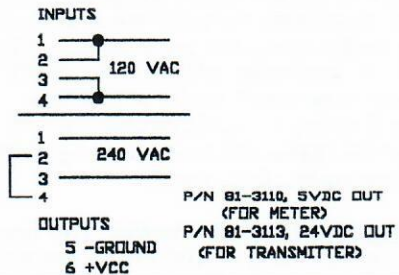

TYPICAL CONNECTIONS FOR RTD INPUT

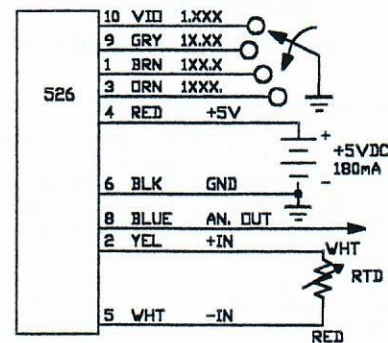

POWER PACK STYLE

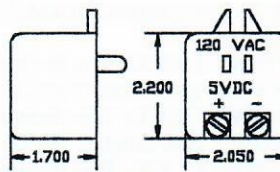

ORDER P/N 75-3110 FOR 5VDC
AND/OR
ORDER P/N 75-2400 FOR 24VDC
(FOR TRANSMITTER)

CONNECTIONS FOR
CURRENT LOOP INPUT

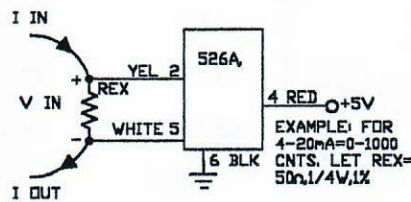

F#87MC526.DWG

FAX: 520-790-2808
E-MAIL: sales@otekcorp.com
TOLL FREE: 1-877-227-6835

520-748-7900

OTTEK™
CORP.

SINCE 1974

4016 E. TENNESSEE ST.
TUCSON, AZ. 85714 U.S.A.

MADE
IN
USA

