

DISCONTINUED!!!!!!! See Model: CTT

NEW

**WORLD'S FIRST POWERLESS™ A.C. LOOP TRANSMITTER,
CONTROLLER FOR: VOLTS-AMPS-WATTS-HERTZ**

**MODEL
ACL
Pat. Pend.**

SPECIFICATIONS

FEATURES:

- Powered By Your **P.T.** or **C.T.!**
- No Power Supply Required
- Only 2 Wires to Connect (P.T. or C.T.)
- No H.V. or H.I. to Your Panel
- 8 Opto Isolated Alarms
- RS232, 485 or USB I/O
- 0-2VDC Out or
- Isolated 4-20mA Out
- Isolated by Your **C.T.** or **P.T.**
- PLC, **OTEK's** Loop Powered Products Compatible
- NEMA 4X Rated Housing
- Panel, Wall, Pipe Mounting



- Conversion Method: True RMS-DC
- Accuracy & Linearity: $\pm 0.1\%$ of F.S.
- Isolation: 500 VRMS on Amps Only
- Input Range: VAC: 50-130VAC & 0.05A-5A; Only AAC: 0.5 - 5 AAC
- Over Range Protection: 150% of Range
- Input Wave Form: Sinosoudal 50-60Hz
- Power Consumption (From Signal): 1/4 Watt
- Min.-Max. Load: 0-500 Ohms
- Max I Out: 26mADC
- Case: NEMA 4X, 1 ea. 1/2" NPT Port
- Op./St. Temp: -10 + 70°C/-20 + 80°C
- CMTBF: $\geq 100K$ Hours
- Warranty: Life Time (Ltd.)

DESCRIPTION:

The World's Largest Manufacturer of Current Loop Products and inventor of Loop Powered Meters, Transmitters and Controllers brings you its new "**ACL**" Series based on its patents #4,908,569; 6,285,094 and other patents pending.

The **ACL** Series consists of dual RMS-DC converters and a 4-20mA transmitter along with either Hz to VDC, VAC-VDC, AAC-VDC or W-VDC converters. All powered by **OTEK's** exclusive VAC (from your potential transformer) to DC converter and/or Amps AC (from your current transformer (C.T.)).

With the **ACL** all you need to do is bring **2 wires** from your power line/load to your panel saving you thousands of dollars on H.V. conduit and safety certifications.

The universally accepted **Current Loop** data process transmission means that you can remotely monitor and control generators, motors, loads, power factor, transmission lines and other critical power related data, without the hazard inherent of high voltage and current wiring.

NOTE: Not Recommended for TRIAC/SCR Firing.

For Option's Specifications, See Text

OTHER RELATED PRODUCTS:

900: Loop Powered Controller

LPT: Loop Powered R.F. Transmitter

LPI: Loop Powered Isolator

ACS: AC Signal Powered Bargraphs & Meters

LBD, LSB, LPB: Loop Powered Bargraphs

LPM, LPE, 521, LPL, LPX: Loop Powered DPMs

PMC: Power/Energy Management Controllers

TAC: Triple A.C. Powerless Quality Meter

Custom: Yours



**If You Don't See
It Ask For It!**

520-748-7900

FAX: 520-790-2808

E-MAIL: sales@otekcorp.com

http://www.otekcorp.com

OTEK™ CORP.

SINCE 1974

4016 E. TENNESSEE ST.
TUCSON, AZ. 85714 U.S.A.

MADE
IN
USA 

ACL

THE OPTIONS: (See Notes on Ordering Information)

The **ACL's** modular design allows us to offer you standard and custom options such as:

1. GRADE (Digit 1):

Industrial: To published specifications. **Mil:** To your supplied specifications. Contact **OTEK** for applicable Mil-Specs. **Nuclear:** Per 10CFR50B through our qualifier **N.L.I.** Telephone #800-448-4124.

2. INPUTS (Digit 2):

You can specify V, A, Hz, W or all four. Use #9 for custom combination or extended ranges beyond specifications and contact **OTEK**.

ACL INPUTS (SIGNAL POWERED)

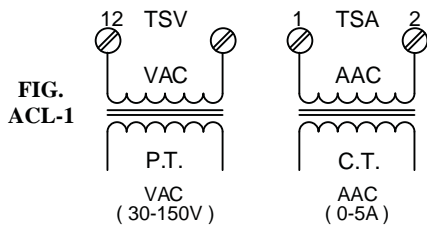

- NOTES: 1.) USE TSV FOR VOLTS OR HERTZ ONLY & 1A Fuse
 2.) USE TSA FOR AMPS ONLY & 10A Fuse
 3.) USE TSV & TSA FOR WATTS

3. DISPLAY (Digit 3): (Only available with 4-20mA output option)

We use our miniature 4-20mA Loop Powered Model **LPL** to give you 4 1/2 (1.9.9.9) digits of 1/2" LCD with backlight. The LPL's Zero and Span adjustments allow for engineering units display (typically calibrated for 0.05A = 4mA = 0062, 5A = 20mA = 10,000 counts). No display under 0.05 Amps or under 50 Volts. Only one display is allowed and will be connected to display output option 5, 6, 7 or 8 on **Digit 4** (Loop Powered).

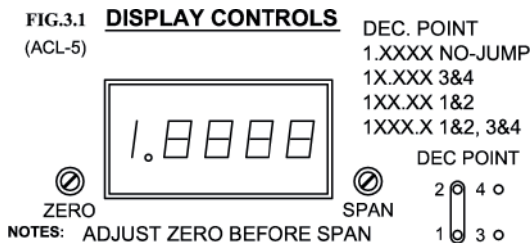

4. OUTPUTS (Digit 4): Note: Options "B" through "M" require external power (Digit 5, Options 1-4), Option 0-A are signal powered (Option 0 on Digit 5).

- Option "0":** None (only for local display of A, V, Hz or W (see display).
 - Option "1":** 0-2VDC for Amps.
 - Option "2":** 0-2VDC for Hertz.
 - Option "3":** 0-2VDC for Volts.
 - Option "4":** 0-2VDC for Watts.
 - Option "5":** 4-20mA for Amps.
 - Option "6":** 4-20mA for Hertz.
 - Option "7":** 4-20mA for Volts.
 - Option "8":** 4-20mA for Watts
 - Option "9":** custom to your specifications. All are **not** isolated from your signal input.
- Note:** Observe min-max loads per Figures 2A & 2B.
- Option "A":** See Option A on Page 3

ACL V & mA OUTPUTS (INTERNALLY POWERED) (OPTIONS 1-8)

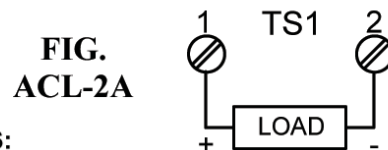

- NOTES:
- 1.) LOAD <= 100 Ω FOR 4-20mA OUT
 - 2.) LOAD >= 100K FOR VDC OUT

ACL 4-20mA OUTPUTS (EXTERNAL COMPLIANCE)

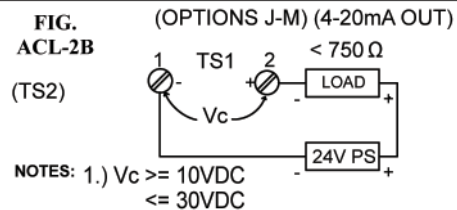

ACL

OPTION A: O.C.T. ALARMS - The **ACL** offers you eight (8) **opto-isolated** (1500VDC/RMS) open collector transistors (O.C.T.) to drive up to 30mADC load and withstand 30VDC (VCE) from their common emitter. The set points can be configured for High, High High, Low, Low Low to any variable (A, Hz, W or V) or Hi & Lo for each variable. The configuration is done via the RS232, 485 or **USB** serial comport (**Non-Isolated** from your **PT** or **CT**). You **must** order Serial Communications, Options 1, 2 or 3 on **Digit 6** when ordering this option.

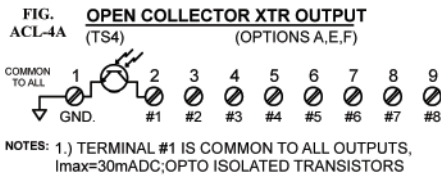

OPTION B: Relay Alarms (4): SPDT 1A max @ 120VAC/30VDC resistive. Must order Power Input options 1-4 on Digit 5.

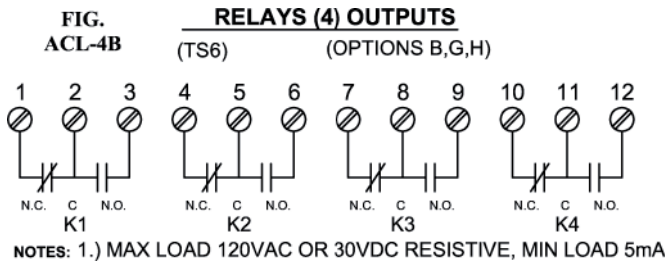

OPTION C: (Requires external power source) - Dual 4-20mA outputs assignable to any 2 variables and factory set (field configurable) for Watts & Amps unless otherwise specified. This option requires Serial I/O to assign the 4-20mA outputs. The Zero and Span for each output are adjustable with included 15 turn potentiometers and they have built-in 30VDC loop power supply so all you need is your load.

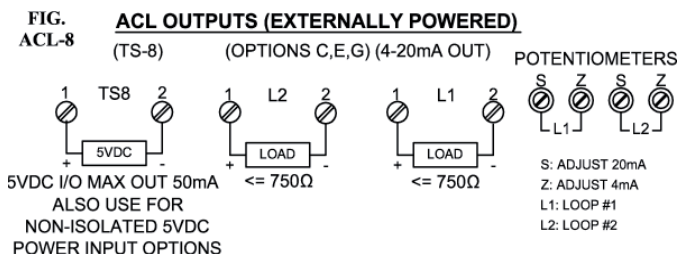

OPTION D: Options C through H are combinations of "1" through "B" as described above.

5. POWER (Digit 5):

The **ACL** is powered by the signal it measures (Volts or Amps). When the signal(s) is too low (below specifications), the **ACL** will **NOT** operate (no display, alarms, Serial I/O, signal output, etc.), just like an analog meter. If you must have the **ACL** operating below these levels then choose the external power options offered (non-isolated 5VDC, isolated 10-32VDC or 90-265VAC). This is especially important when measuring Amps below 0.05A or Volts below 50VAC or when Serial Communications (Digit 6) or alarms (digit 3) are ordered.

ISOLATED POWER INPUT

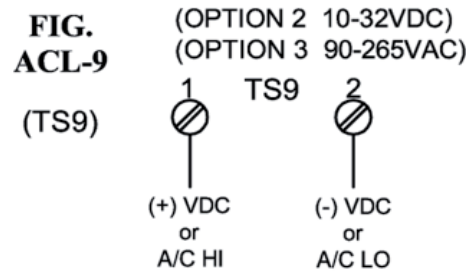

NOTES: VERIFY POWER INPUT BEFORE CONNECTING

6. SERIAL I/O (Digit 6): WARNING: No isolation to Powerless™ versions or signal input. Isolated when options 2 or 3 of digit 5 is included.

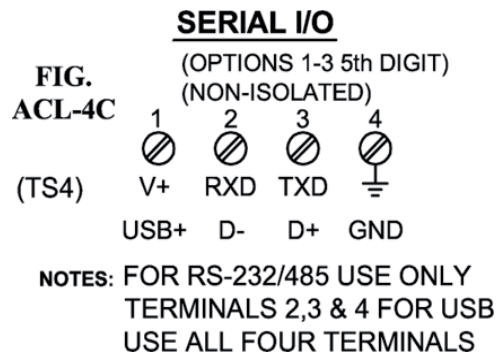

ACL

Options J-M: These are 4-20mA outputs requiring external compliance (~24VDC) and require **NO** Serial I/O (Digit 6, Option 0). Zero and span adjusts for 4-20mA via potentiometers. The external compliance increases the load range to ~750 Ohms versus <100 Ohms of Options 5-8. In other words, options 5-8 are signal powered and can drive <=100 Ohm load; Options J-M are externally powered and can drive any ohmic load so long as the VC=>10<30 VDC (see Fig. ACL-2B).

SPECIFICATIONS FOR OPTIONS:

Display: LCD 4 1/2 digits, 0.4" high, red (Option 1); Green (Option 2) backlit, positive image; or 4 digit 0.25 LED (Option 3).

Power (External): 5VDC non-isolated, $\pm 10\%$, Max. 1/2 Amp. 10-32VDC isolated, Max. 2.5 Watts. 90-265VAC isolated, 50-60Hz, Max. 2.5 Watts.

USB Powered: You can power the **ACL** from your **USB** port since the **ACL** requires 5VDC at 1/2A or less (max. allowed from **USB** port), but **no isolation** exists!

Analog Outputs: Non-Isolated from input signals (**Must** use P.T. or C.T.). Accy. & Lin.: $\pm 0.1\%$ of full scale.

Serial I/O: Compliant to their own standard. Open Protocol ASCII, 8N1, 2400 to 19.2K Baud. Non-Isolated from signal input. Download drivers free from our website at support/downloads.

Alarms: (Set-Points): Accuracy: 10 Bit (0.1% of F.S.) Type: O.C.T. with one common emitter connection. Optical isolation to other I/O: 1500VDC/RMS, VCE: 30VDC, IC: 30mA (2N3904 Type).

Dual 4-20mA Outputs: External power required: 5, 10-32VDC or 90-265VAC to power internal 5-30VDC DC-DC to supply loop power. (**No** isolation exists between the **Loops**) Accuracy & Linearity: $\pm 0.1\%$ of F.S., Min-Max output current: 3.6 - 36mA, Max. V Out: 30VDC, Min-Max Load: 0-750 Ohms.

Dual 0-2VDC Analog Outputs: (Powered by the input signals or external power): Accuracy & Linearity: $\pm 0.1\%$ of F.S., Min. Load: >10K Ohms, Isolation from input signals: None

Potential and Current Transformers: P.T. are used to isolate and step down H.V. mains and normally one side of the P.T. secondary is earth grounded for safety. To avoid ground lops, connect the **ACL's** VAC low input at the same point. **C.T.** are used to isolate and step down high A.C. mains current. Connect the **ACL** as close to the **C.T.** as possible and use 12 ga. wire. Use a **C.T.** with "shorting bar" and **never** make connections to **P.T.** or **C.T.** while powered! Use electrical codes std. **PTs** are classified and known as: 1:1, 10:1, 10,000:1, etc. and all (or most) have 120VAC output for a given input. **CTs** are classified and knows as: 10:5, 100:5, 1000:5, etc. and it means that their output (5A) corresponds to a given F.S. input.

NEMA 4 X MECHANICAL

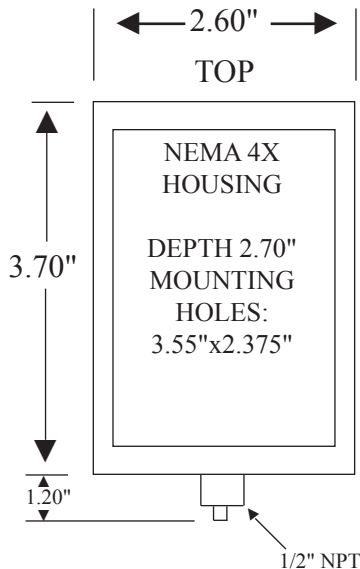
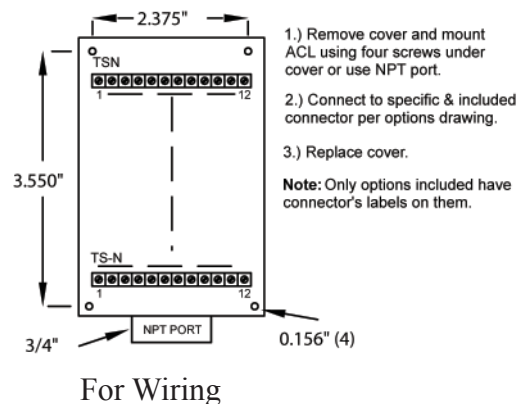
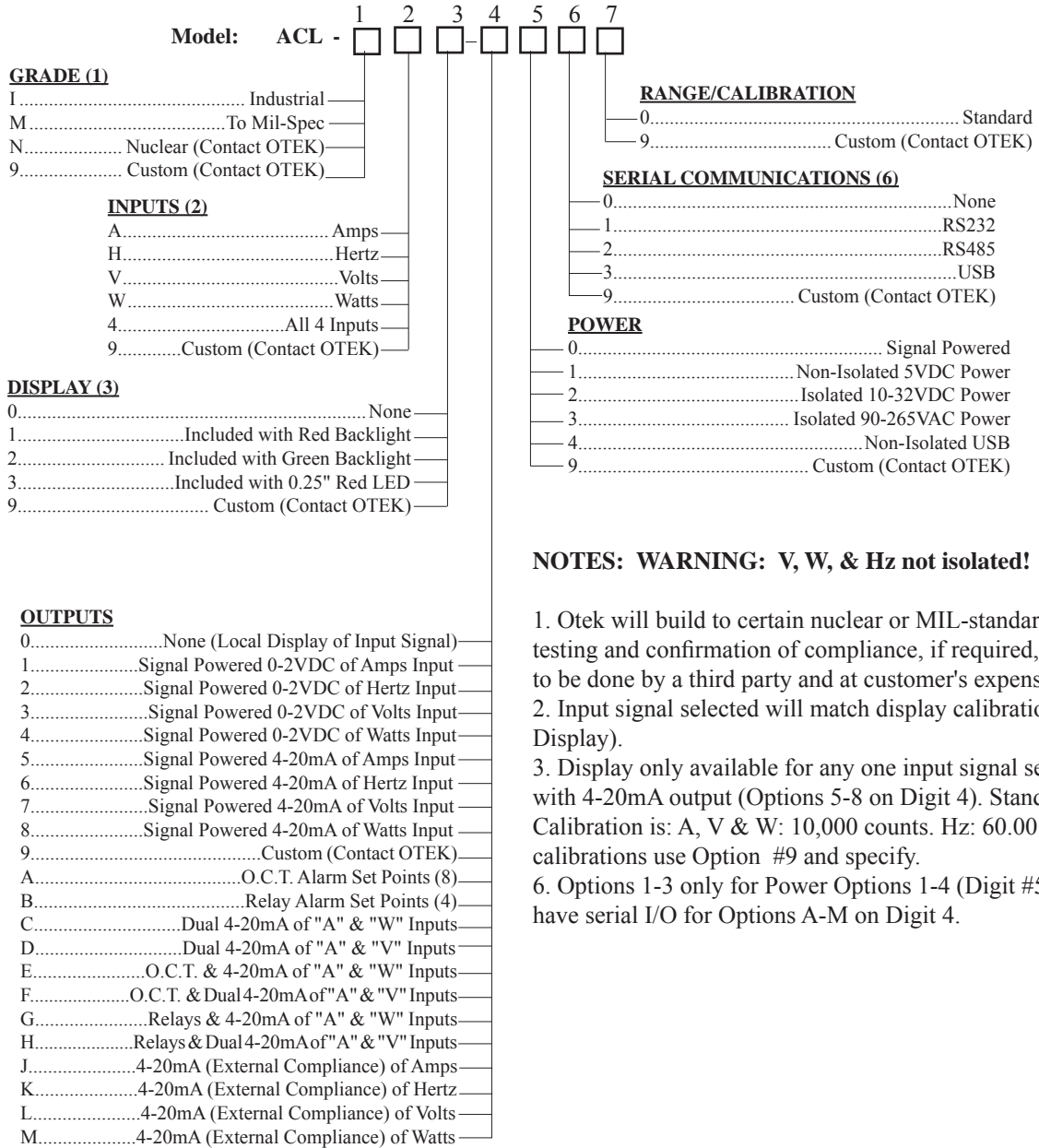

FIG. ACL-0
ACL CONNECTIONS
MOUNTING AND WIRING INSTRUCTIONS



NOTE: Please READ BEFORE building part number:

1. If digit 4 is option 0 through 8, then digits 5 and 6 must be 0 (and conversely).
2. If digit 4 is option B-H, then digit 5 must be option 1, 2, 3 or 4 (and conversely).
3. See notes at bottom of page.



NOTES: WARNING: V, W, & Hz not isolated!

1. Otek will build to certain nuclear or MIL-standards but testing and confirmation of compliance, if required, will need to be done by a third party and at customer's expense.
2. Input signal selected will match display calibration (See Display).
3. Display only available for any one input signal selected and with 4-20mA output (Options 5-8 on Digit 4). Standard Calibration is: A, V & W: 10,000 counts. Hz: 60.00. Other calibrations use Option #9 and specify.
6. Options 1-3 only for Power Options 1-4 (Digit #5). Must have serial I/O for Options A-M on Digit 4.